

INTER[®]

EXCELLENT ENGINE

TIER III
EMISSIONS
FAMILY

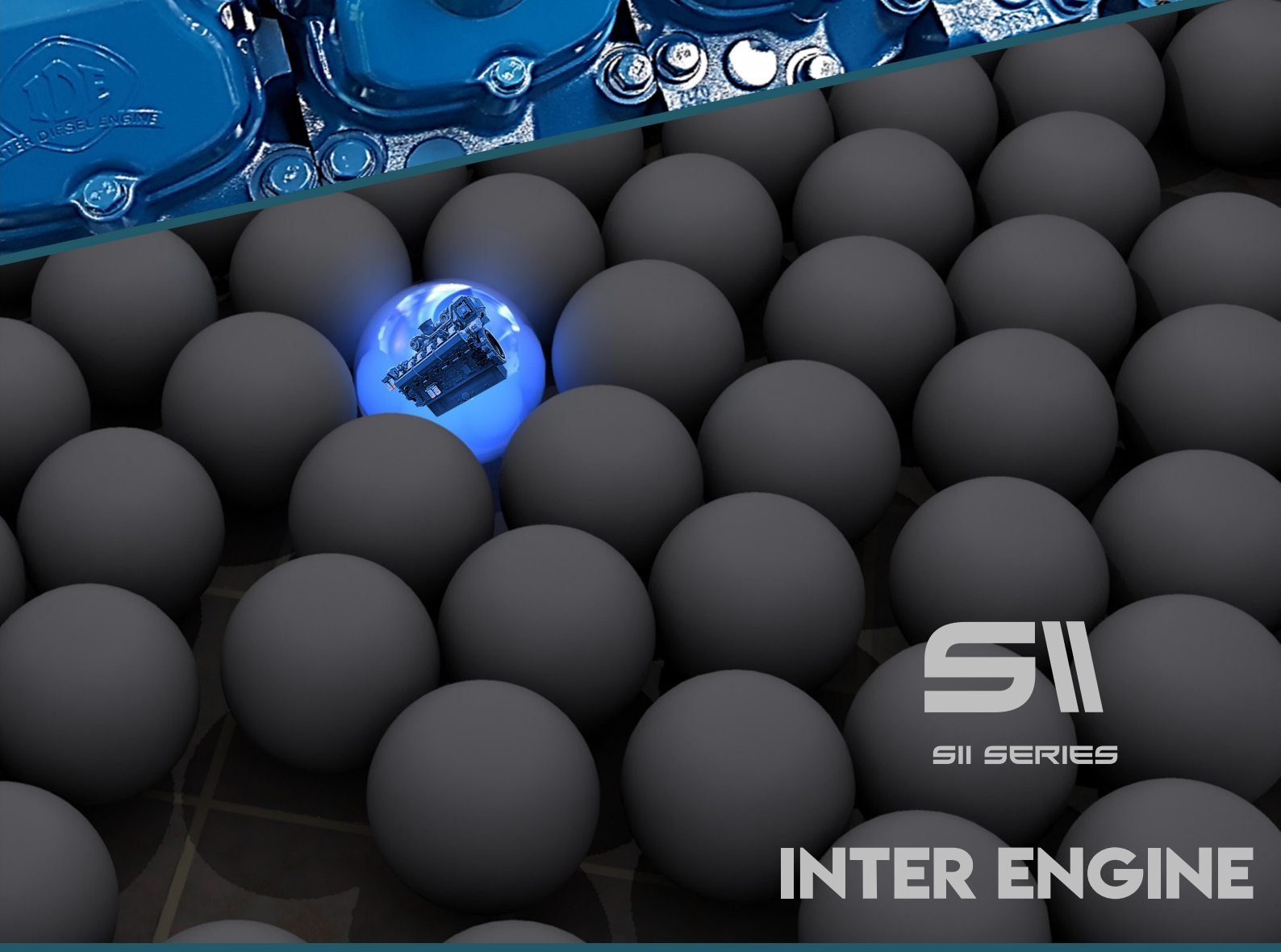
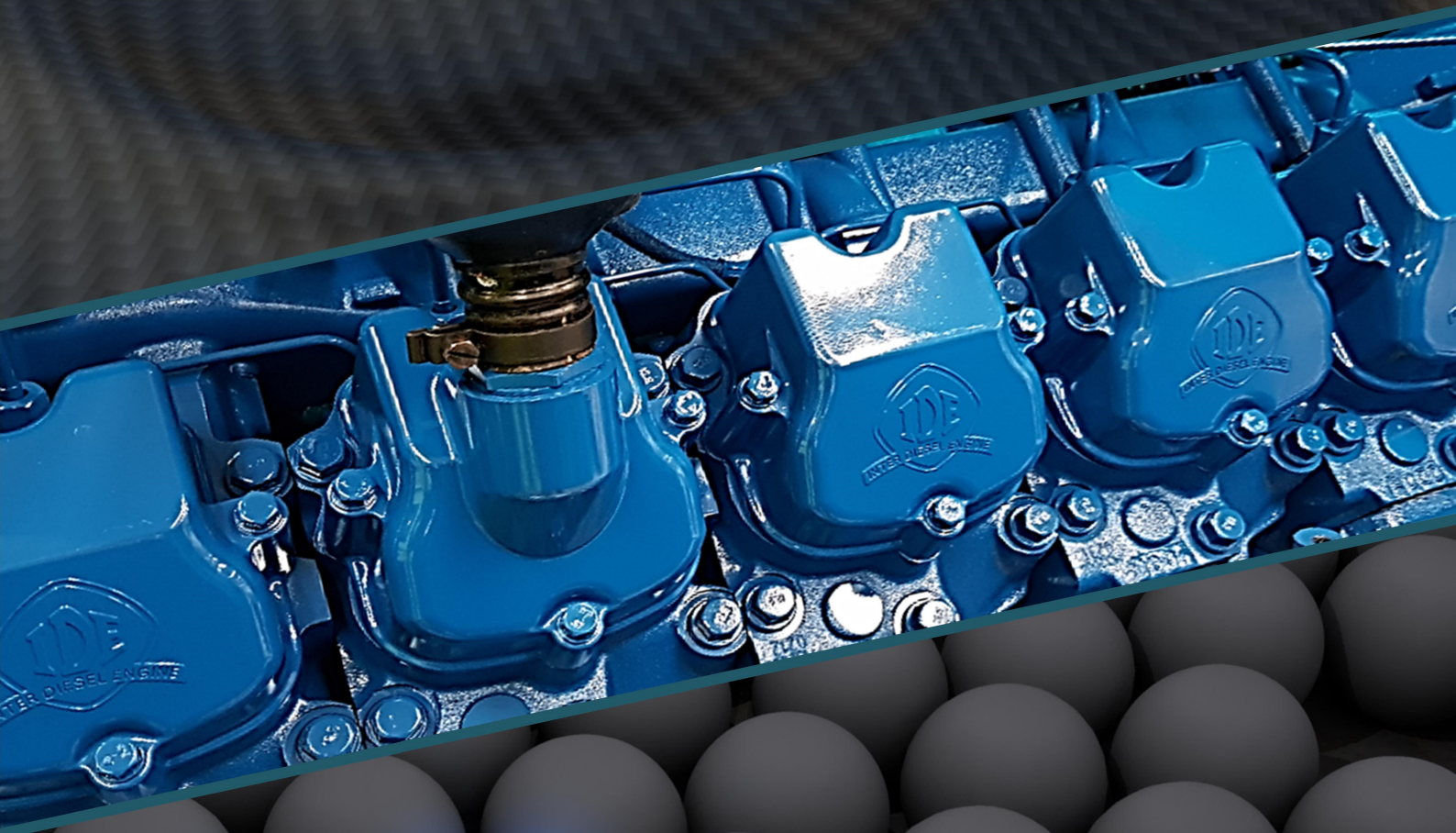

SII

SII SERIES

INTER ENGINE

INTER[®]

EXCELLENT ENGINE

TIER III

EMISSIONS

FAMILY

GLOBAL



FACILITIES



About INTER

INTER DIESEL ENGINE was first established in USA in 1927 as an independent engine manufacturer.

Right now, they manufacture high quality diesel engines from 2 cylinders to 20 cylinders, in the factories that are in Brazil, Argentina, India and China. They manufacture with their original design.

Apart from their own factories, in order to serve and meet the customer needs in other areas, they have their offices and distributors in Germany, UK, Spain, Italy, Turkey and South Africa. These distributors and offices deals with sales, after sales services and spare part supply.

INTER DIESEL ENGINE produces diesel engines from 7.5 kW to 3000kW to be used in agricultural equipment's, trucks, buses, tractors, construction equipment, generators, boats and ships.

They export to more than 100 countries and have 45 distributors, 160 dealers and more than 200 after sales service. With this service network, Inter Diesel Engine increases its global market share every day.

FEATURES AND BENEFITS

- Excellent Design
- High and Dependable Technology
- Heavy Duty
- Durability
- Low Noise
- Low Exhaust Emission
- Low Operating Cost
- World Class Product Support
- Flexible Application
- Direct Injection
- Tier II / Tier III / Tier IV Emission Regulations
- Low Fuel Consumption
- Low Oil Consumption
- Tropical Radiator
- Easy Service & Maintenance
- Mechanical / Electronic Governor
- Compact Design
- Noise Optimized Engine Design

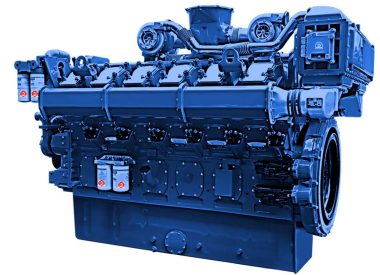

Diesel Engine and Genset Rating Classifications

The below ratings represent the engine performance capabilities to conditions specified in TS ISO 8528/1, 8528-4, 8528-5, 8528-8, BS5000, ISO 3046/1:1986, NEMA MG-1.22.1, BS 5514/1.

STAND BY POWER RATING (ESP):

ESP is applicable for supplying emergency power for the duration of the utility power outage. No overload capability is available for this rating. Under no condition is an engine allowed to operate in parallel with the public utility at the Stand By Power rating. This rating should be applied where reliable utility power is available. A Stand By rated engine should be sized for a maximum of an 70% average load factor and 200 hours of operation per year. This includes less than 25 hours per year at the Stand By Power rating. Stand By ratings should never be applied except in true emergency power outages. Negotiated power outages contracted with a utility company are not considered an emergency.

PRIME POWER RATING (PRP):

Applicable for supplying electric power in lieu of commercially purchased power. Prime Power applications must be in the form of one of the following two categories:

UNLIMITED TIME RUNNING PRIME POWER (ULTP):

PRP (Prime Power) is available for an unlimited number of hours per year in a variable load application. Variable load should not exceed a 70% average of the Prime Power rating during any operating period of 250 hours. The total operating time at 100% Prime Power shall not exceed 500 hours per year. A 10% overload capability is available for a period of 1 hour within a 12-hour period of operation. Total operating time at the 10% overload power shall not exceed 25 hours per year.

LIMITED TIME RUNNING PRIME POWER (LTP):

LTP (Limited Time Prime Power) is available for a limited number of hours in a nonvariable load application. It is intended for use in situations where power outages are contracted, such as in utility power curtailment. Engines may be operated in parallel to the public utility up to 750 hours per year at power levels never to exceed the Prime Power rating. The customer should be aware, however, that the life of any engine will be reduced by this constant high load operation. Any operation exceeding 750 hours per year at the Prime Power rating should use the Continuous Power rating.

CONTINUOUS POWER RATING (COP):

COP is the power that the engine can continue to use under the prescribed speed and the specified environment condition in the normal maintenance period stipulated in the manufacturing plant. And Continuous Power is applicable for supplying utility power at a constant 100% load for an unlimited number of hours per year. No overload capability is available for this rating.

E3091CRDIT

79,17 Liter, V Type 12 Cylinder

G Drive Engine

INTER[®]

EXCELLENT ENGINE

TIER III

EMISSIONS

FAMILY

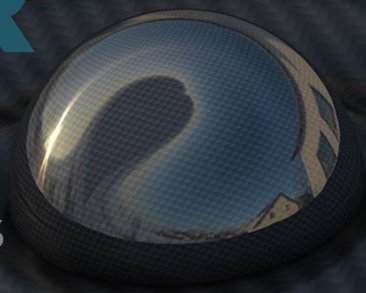

E3091CRDIT

TECHNICAL DATA SHEETS

Diesel Engine Main Technical Parameters

General

Number of Cylinders		12
Configuration		V - Type
Aspiration		Turbocharged & Intercooled
Combustion System		Common Rail
Compression Ratio		13.5:1
Bore	mm	200
Stroke	mm	210
Displacement	L	79,17
Governing Type		ECU
Governing Class		G3
Rotation		Counterclockwise
Firing Order		L1-R6-L5-R2-L3-R4-L6-R1-L2-R5-L4-R3
Emission		Tier III

Moments of Rotation Inertia

Engine	kg • m ²	39,53
Flywheel	kg • m ²	25,05

Performance Rating

Speed Droop	%	≤0.5
Steady State Speed Band	%	≤0.5

Test Conditions

Ambient Temperature	%	25
Atmospheric Pressure	kPa	100
Relative Humidity	RH (%)	30
Max. Operating Intake Resistance	kPa	<5
Exhaust Backpressure Limit	kPa	<10
Fuel Temperature (Fuel Inlet Pump)	°C	38 ± 2

Filters

Air Filter		Dry Type, Replaceable
Fuel Filter		With Water Separator
Oil Filter		Element Type, Particulate Trap

Flywheel Housing and Flex Coupling

Flywheel Housing	SAE (J620)	00
Flex Coupling Disc	Inch (")	21

Overall Dimensions

Length *	mm	3320
Width	mm	2560
Height	mm	2255
Dry Weight	Kg	9707

* From front end of radiator to rear end of air filter

Cooling System

Radiator Type	50°C	Tropical
Total Coolant Capacity	L	355
Max. Perm. Coolant Outlet Temperature	°C	105
Max. Perm. Flow Resis. (Cool. System And Piping)	bar	0,5
Max. Temperature of Coolant Warning	°C	95
Max. Temperature of Coolant Shutdown	°C	98
Thermostat Operation Temperature - Initial Open	°C	75
Thermostat Operation Temperature - Full Open	°C	85
Delivery of Coolant Pump	m ³ / h	16,67
Min. Pressure Before Coolant Pump	bar	0,5
Radiator Face Area	m ²	5,35
Rows	Row	7
Matrix Density	Per / Inch	12
Material		Aluminum
Width of Matrix	mm	2559
Height of Matrix	mm	2086
Pressure Cap Setting	kPa	50
Estimated Cooling Air Flow Reserve	kPa	0,125
Engine Pre Heater Tube (with Circulation Pump)	W	2x4500

Lubrication System

Total System	L	340
Minimum Oil Level	L	280
Nominal Motor Operating Temperature	°C	40
Lubricating Oil Pressure (Rated Speed)	bar	7
Relief Valve Opens	kPa	200
Oil / Fuel Consumption Ratio	%	≤0.1
Normal Oil Temperature	°C	110

Electrical System

Voltage	V	24
Starter	kW	2X11
Alternator Output Amperes	A	60
Alternator Output Voltage	V	28
Batteries Capacity	Ah	4X200

Fan

Diameter	mm	1700
Drive Ratio		1:26
Number of Blades		8
Material		PAG
Type		Blowing

Diesel Engine Matching Parameters

50 Hz @ 1500 r/min

		Stand By	Prime
Gross Engine Power	kW	2160,0	1970,0
Net Engine Power	kW	2085,0	1895,0
Fan Power Consumption (Belt Pulley Driven)	kW	70,0	70,0
Other Power Loss	kW	5,0	5,0
Mean Effective Pressure	MPa	1,97	1,78
Intake Air Flow	m ³ / min	175,00	159,00
Exhaust Temperature Limit	°C	550	550
Exhaust Flow	m ³ / min	395,00	358,00
Boost Pressure Ratio		3,15	2,88
Mean Piston Speed	m / s	10,5	10,5
Cooling Fan Air Flow	m ³ / min	3000,0	3000,0
Typical Generator Output Power	kVA	2502	2274

Heat Rejection

Energy in Fuel (Heat of Combustion)	kW	5093,0	4598,0
Gross Heat to Power	kW	2160,0	1970,0
Energy to Coolant and Lubricating Oil	kW	690,0	621,0
Heat Dissipation Capacity*	kW	820,0	738,0
Energy to Exhaust	kW	1205,0	1065,0
Heat to Radiation	kW	218,0	204,0

*Intake Intercooled System

60 Hz @ 1800 r/min

		Stand By	Prime
Gross Engine Power	kW	2160,0	1970,0
Net Engine Power	kW	2085,0	1895,0
Fan Power Consumption (Belt Pulley Driven)	kW	70,0	70,0
Other Power Loss	kW	5,0	5,0
Mean Effective Pressure	MPa	1,97	1,78
Intake Air Flow	m ³ / min	175,00	159,00
Exhaust Temperature Limit	°C	550	550
Exhaust Flow	m ³ / min	395,00	358,00
Boost Pressure Ratio		3,15	2,88
Mean Piston Speed	m / s	10,5	10,5
Cooling Fan Air Flow	m ³ / min	3000,0	3000,0
Typical Generator Output Power	kVA	2502	2274

Heat Rejection

Energy in Fuel (Heat of Combustion)	kW	5093,0	4598,0
Gross Heat to Power	kW	2160,0	1970,0
Energy to Coolant and Lubricating Oil	kW	690,0	621,0
Heat Dissipation Capacity*	kW	820,0	738,0
Energy to Exhaust	kW	1205,0	1065,0
Heat to Radiation	kW	218,0	204,0

*Intake Intercooled System

EXCELLENT ENGINE

TIER III

EMISSIONS

FAMILY

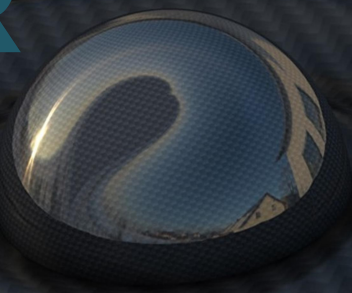

POWER RANGE

FUEL CONSUMPTION

OIL GRADES

DIMENSION

DIAGRAMS

INTER Diesel Engine Power Ratings

Engine Model	E3091CRDIT	Engine Family	ID37	Engine Series	SII		
Speed rpm	Type of Operation	Typical Generator Output (Net)		Engine Power			
				Gross		Net	
		kVA	kWe	kWm	Hp	kWm	Hp
1500	Stand By (Maximum)	2.502,0	2.002,0	2.160,0	2.899,3	2.085,0	2.798,7
	Prime	2.274,0	1.819,0	1.970,0	2.644,3	1.895,0	2.543,6
1800	Stand By (Maximum)	2.502,0	2.002,0	2.160,0	2.899,3	2.085,0	2.798,7
	Prime	2.274,0	1.819,0	1.970,0	2.644,3	1.895,0	2.543,6

Generator powers are typical and are based on an average alternator efficiency and a power factor (Cos. Q) of 0.8

SAE GRADES

For Engine Oils Recommended in Relation with the Outside Temperature °C

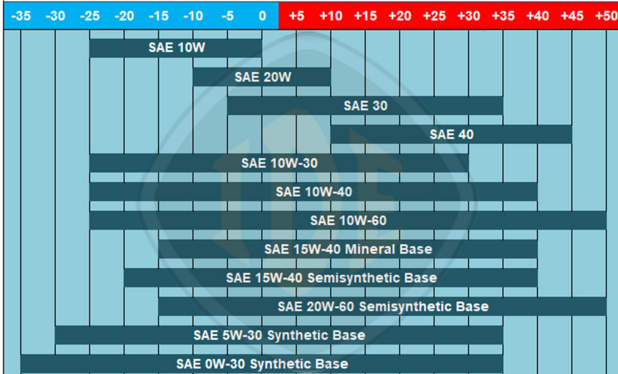

INTER ENGINE Recommendation: SAE 15W40 to API C4 Viscosity Lubricating oil, mono-grade or multi-grade Diesel Engine oil

Fuel Consumption

Percent of Prime power	50Hz - 1500 rpm	60Hz - 1800 rpm
	l/hr	l/hr
110%	497,30	497,30
100%	455,85	455,85
75%	343,60	343,60
50%	240,52	240,52

Note: At calorific value 42700 kJ/kg + 5 %, density 0.860 kg/dm³, temperature 280 K.

Fuel specification: BS 2869: Part 2 1998 Class A2 or (DIN EN 590) ASTM D975 D2 Diesel. The fuel must be clean and without water

INTER ENGINES MAIN AND BIGGEST PARTNERS

INTER[®]
ENGINE GROUP



North America Business Unit
NAFTA

Mercosur Business Unit
MERCOSUR

Global Business Unit

Diesel Engine Appearance and Installation Dimension Diagram

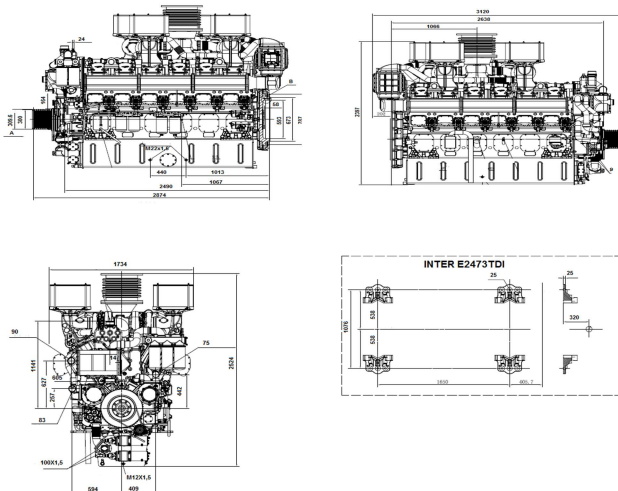

INTER[®]
ENGINE GROUP